

SK2U200-400 Ultrafast Recovery Modules

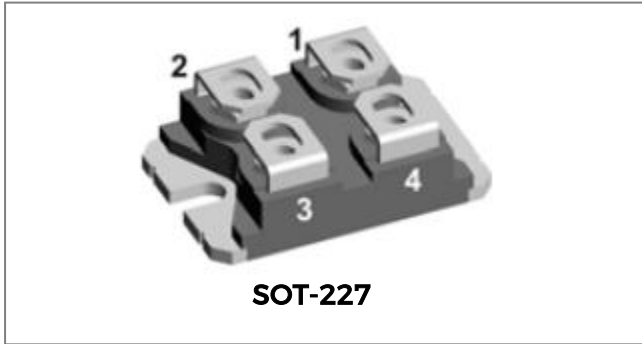

Features

- Two fully independent diodes
- Fully insulated package
- Ultrafast, soft reverse recovery, with high operation junction temperature (175°C T_J)
- Low forward voltage drop
- Optimized for power conversion: welding and industrial SMPS applications
- Easy to use and parallel
- Industry standard outline
- Designed and qualified for industrial level
- This is a Pb - Free Device
- All SMC parts are traceable to the wafer lot
- Additional testing can be offered upon request

Circuit Diagram

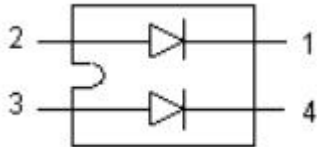

Maximum Ratings:

| Characteristics | Symbol | Condition | Max. | Units |
|--|-------------------|---|------|-------|
| Cathode to anode voltage | V _R | - | 400 | V |
| Continuous forward current per diode | I _{F(1)} | T _C = 111°C, In DC | 120 | A |
| Single pulse forward current per diode | I _{FSM} | 8.3 ms, half Sine pulse, T _C = 25°C | 600 | A |
| RMS isolation voltage | V _{isol} | Any terminal to case, t=1 minute | 2500 | V |
| Maximum power dissipation per module | P _D | T _C = 90°C | 311 | W |

Note: (1) Maximum continuous forward current must be limited to 100A to do not exceed the maximum temperature of power terminations.

Electrical Characteristics:

| Characteristics | Symbol | Condition | Min. | Typ. | Max. | Units |
|------------------------------------|-----------|---|------|------|------|---------|
| Cathode to anode breakdown voltage | V_{BR} | @ $I_R = 100\mu A$ | 400 | - | - | V |
| Forward Voltage Drop (per leg) * | V_{F1} | @ 100A, Pulse, $T_J = 25^\circ C$ | - | 1.08 | 1.15 | V |
| | V_{F2} | @ 100A, Pulse, $T_J = 125^\circ C$ | - | 0.92 | 1.0 | V |
| Reverse Current (per leg) * | I_{R1} | @ $V_R = \text{rated } V_R, T_J = 25^\circ C$ | - | 0.03 | 50 | μA |
| | I_{R2} | @ $V_R = \text{rated } V_R, T_J = 125^\circ C$ | - | 0.06 | 2 | mA |
| Reverse recovery time | t_{rr} | $I_F = 500mA, I_R = 1A, \text{ and } I_{rm} = 250mA$ | - | 120 | 150 | nS |
| Reverse Recovery Time | t_{rr} | $I_F = 1A, diF/dt = 50A/\mu s, V_R = 30V, T_J = 25^\circ C$ | - | 68 | - | ns |
| Reverse Recovery Time | t_{rr} | $I_F = 30A, diF/dt = 200A/\mu s, V_R = 200V, T_J = 25^\circ C$ | - | 107 | - | ns |
| Reverse Recovery Charge | Q_{rr} | | - | 1850 | - | nC |
| Reverse Recovery Current | I_{RRM} | | - | 15 | - | A |
| Reverse Recovery Time | t_{rr} | $I_F = 30A, diF/dt = 200A/\mu s, V_R = 200V, T_J = 125^\circ C$ | - | 196 | - | ns |
| Reverse Recovery Charge | Q_{rr} | | - | 3110 | - | nC |
| Reverse Recovery Current | I_{RRM} | | - | 26.6 | - | A |

* Pulse width < 300 μs , duty cycle < 2%

Thermal-Mechanical Specifications:

| Characteristics | Symbol | Condition | Specification | Units |
|--|-----------------|-----------------------|---------------|--------------|
| Junction Temperature | T_J | - | -55 to +175 | $^\circ C$ |
| Storage Temperature | T_{stg} | - | -55 to +175 | $^\circ C$ |
| Maximum Thermal Resistance Junction to Case(per leg) | $R_{\theta JC}$ | DC operation | 0.56 | $^\circ C/W$ |
| Maximum Thermal Resistance Junction to Case(per package) | $R_{\theta JC}$ | DC operation | 0.28 | $^\circ C/W$ |
| Typical Case to heatsink | $R_{\theta JS}$ | Flat, greased surface | 0.075 | $^\circ C/W$ |
| Typical Mounting Torque | T_M | - | 1.3 | Nm |
| Typical Approximate Weight | wt | - | 30 | g |

Ordering Information

| Device | Package | Shipping |
|-------------|-------------------|-------------|
| SK2U200-400 | SOT-227 (Pb-Free) | 36pcs /BULK |

For information on tape and reel specifications, including part orientation and tape sizes, please refer to our tape and reel packaging specification.

Marking Diagram

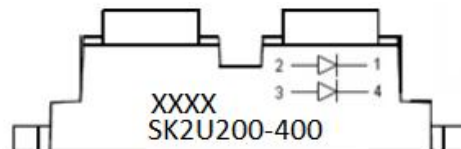

Where XXXX is YYWW

- S = SMC's Power Module
- K = SOT-227 Package
- 2 = Circuit Configuration
- U = Ultrafast Rectifier
- 200 = Forward Current (200A)
- 400 = Reverse Voltage (400V)
- YY = Year
- WW = Week

Remark: marking is as above from data code 2036.

Mechanical Dimensions SOT-227(Millimeters)

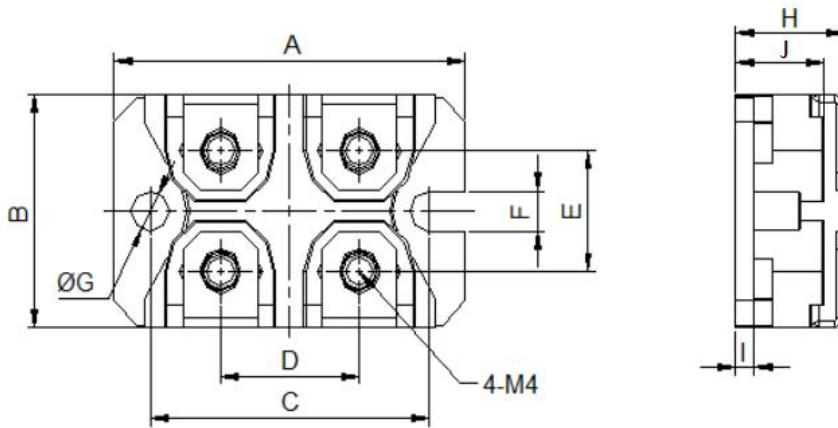

| SYMBOL | Dimensions in millimeters | |
|--------|---------------------------|-------|
| | Min. | Max. |
| A | 37.80 | 38.20 |
| B | 25.00 | 26.00 |
| C | 29.90 | 30.50 |
| D | 14.50 | 15.50 |
| E | 12.20 | 13.20 |
| F | 4.10 | 4.50 |
| G | φ4.1 | φ4.5 |
| H | 11.00 | 12.00 |
| I | 1.90 | 2.10 |
| J | 9.00 | 10.00 |

DISCLAIMER:

- 1- The information given herein, including the specifications and dimensions, is subject to change without prior notice to improve product characteristics. Before ordering, purchasers are advised to contact the SMC Diode Solutions sales department for the latest version of the datasheet(s).
- 2- In cases where extremely high reliability is required (such as use in nuclear power control, aerospace and aviation, traffic equipment, medical equipment, and safety equipment), safety should be ensured by using semiconductor devices that feature assured safety or by means of users' fail-safe precautions or other arrangement.
- 3- In no event shall SMC Diode Solutions be liable for any damages that may result from an accident or any other cause during operation of the user's units according to the datasheet(s). SMC Diode Solution assumes no responsibility for any intellectual property claims or any other problems that may result from applications of information, products or circuits described in the datasheets.
- 4- In no event shall SMC Diode Solutions be liable for any failure in a semiconductor device or any secondary damage resulting from use at a value exceeding the absolute maximum rating.
- 5- No license is granted by the datasheet(s) under any patents or other rights of any third party or SMC Diode Solutions.
- 6- The datasheet(s) may not be reproduced or duplicated, in any form, in whole or part, without the expressed written permission of SMC Diode Solutions.
- 7- The products (technologies) described in the datasheet(s) are not to be provided to any party whose purpose in their application will hinder maintenance of international peace and safety nor are they to be applied to that purpose by their direct purchasers or any third party. When exporting these products (technologies), the necessary procedures are to be taken in accordance with related laws and regulations.